

# INSTALL GUIDE

## CSEN1



**Part Numbers:** CSEN1-H-W-ZHA (white enclosure) and CSEN1-H-G-ZHA (gray enclosure)

## DESCRIPTION

The CSEN1 is a low voltage Networked Lighting Controller with an integrated passive infrared sensor and a photocell. It is powered via the AUX power from the LED driver. The CSEN1 autodetects both 0-10V Drivers and D4i Drivers to simplify the installation. The product is DLC certified for both indoor and outdoor applications.

## SPECIFICATIONS

- Radio Frequency: 2.4 GHz (IEEE 802.15.4)
- RF Transmission Output Power: +20dBm
- Operating Temperature: -40° to +70° C
- Operating Humidity: 10 to 95%, non-condensing
- IP66 Rated Enclosure
- Dimensions: 3.1" D x 1.6" H (80mm D x 42mm H)
- Input Power: 12-24VDC, 35mA max, 840mW
- Purpose of control: Operating
- Environmental: Indoor/Outdoor
- Pollution Degree: 3
- Rated Impulse Voltage: 330V

## DESIGN CONSIDERATIONS

Below are some recommendations for successful analog dimming using the CSEN1. The analog dimming control wires are referenced as DALI+/DIM+ and Common Ground/DALI-. The dimming signals have a Maximum voltage of 10V DC.

- Do not ground the Common Ground/DALI- wire to chassis ground; this is a return signal and is critical for proper dimming.
- Route dimming wires away from AC lines if possible.
- Maximum of 4 DALI-2/D4i LED Drivers per controller, consult Synapse Support if a greater ratio is needed.
- Maximum of 8 DIM to OFF LED Drivers for DIM to OFF Designs.
- Do not mount to a heatsink or to an LED driver.

**NOTE:** LED Driver must support DIM to OFF functionality.

## WARNINGS AND CAUTIONS

- **TURN OFF POWER AT CIRCUIT BREAKER OR FUSE AND TEST THAT POWER IS OFF BEFORE INSTALLING OR SERVICING!**
- The CSEN1 should only be installed in a fixture with a Zhaga Book 18 receptacle.
- Failure to follow these instructions and warnings could potentially void the warranty.
- This product must be installed in accordance with national, state, and local electrical codes and requirements.
- If you are unsure about any part of these instructions, consult an electrician; qualified personnel should perform all work.

## WIRING DETAILS OF ZHAGA BOOK 18 SOCKET

**TURN OFF POWER AT CIRCUIT BREAKER OR FUSE AND TEST THAT POWER IS OFF BEFORE INSTALLING OR SERVICING!**

For fixtures with an existing Zhaga socket, prior to installation, verify the wiring per the details below. **(See Figure 1)**

If the fixture does not have a Zhaga socket, use the appropriate Wired Adapter accessory based on the knockout size: CSEN1-ZHA-ADPT-22 for 22mm knockouts, or CSEN1-ZHA-ADPT-33 for 33mm knockouts. The specifications for the signal wires are:

- 12-24VDC POWER: Brown
- Common Ground/DALI-: Pink with White Stripe
- DALI+/DIM+: Violet with White Stripe
- Solid Conductor, 105°C, Rated for 600VAC, AWG 20, 15" Length

FIGURE 1

Bottom View of the  
CSEN1

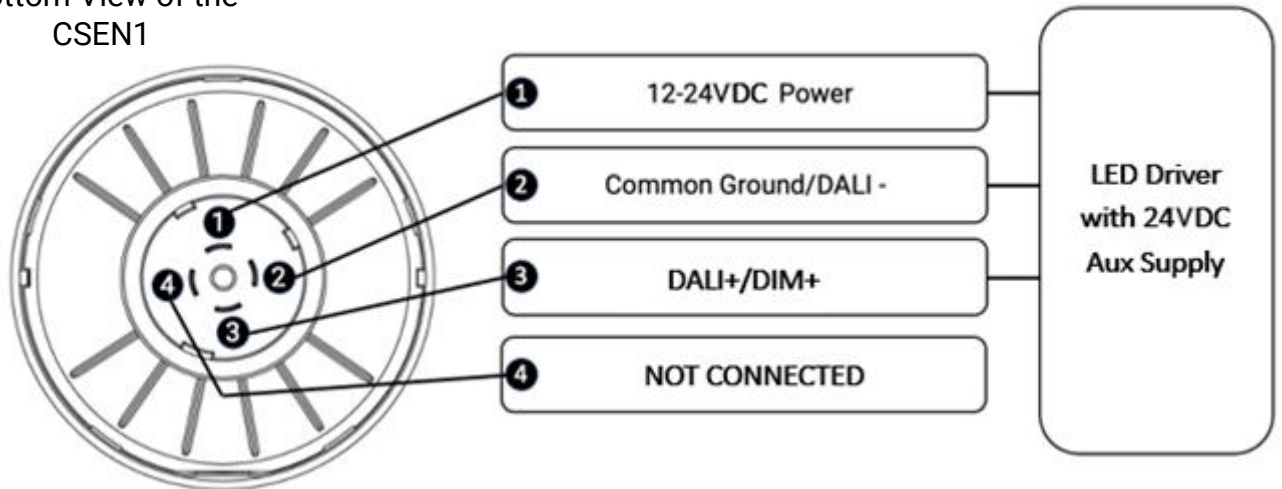

Note the key  
location at the bottom



# INSTALLATION INSTRUCTIONS

**TURN OFF POWER AT CIRCUIT BREAKER OR FUSE AND TEST THAT POWER IS OFF BEFORE INSTALLING OR SERVICING!**

1. If applicable, remove the sealing cap or lighting control device currently installed in the fixture receptacle.
2. Align the CSEN1 such that the contacts pins are positioned at the appropriate the receptacle contacts.
3. After alignment, push until the CSEN1 is fully seated within the receptacle.
4. While pushing against the device, twist the CSEN1 housing clockwise until it locks into place. The CSEN1 includes a latching key or notch that will lock into position with an audible “click”. **(See Figure 2)**

**Note:** To function properly, make sure the controller is inserted completely into the socket and twisted into the locked position.

**Note:** Upon power up, the device will turn on the lamps to 100%, then ramp down to off over 2 seconds, stay off for 2 seconds, and then ramp back up to 100% over 2 seconds.

**Warning:** The Zhaga receptacle should not turn during installation. Turning the receptacle could damage the internal fixture wiring by pulling it loose.

**FIGURE 2**

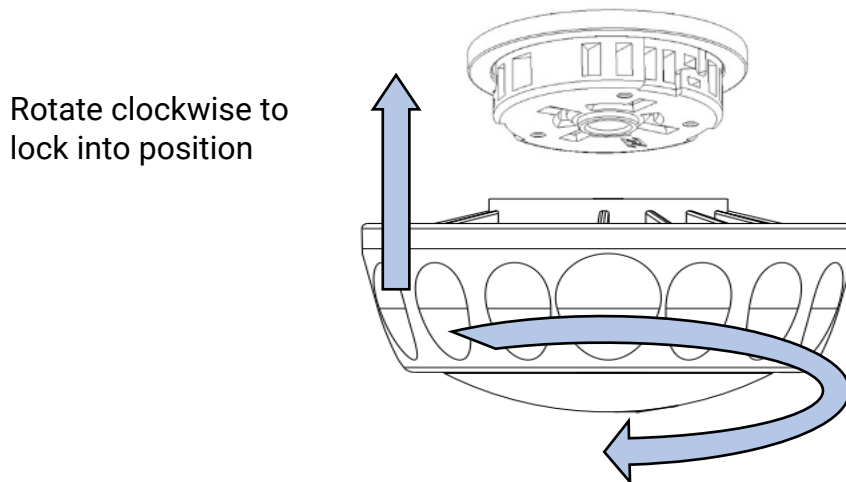

## STATUS LEDS

Power LED	Status
Blue	On for 3 seconds at Startup, then Off
Status LED	Status
Red	No script on the device
Blinking Red	Communication Error
Blinking Blue	Communication, No Config
Blinking Green	Normal Operation with Motion
Off	Normal Operation, no Motion

# REGULATORY INFORMATION AND CERTIFICATIONS

**RF Exposure Statement:** This equipment complies with FCC radiation exposure limits set forth for an uncontrolled environment. This equipment should be installed and operated with minimum distance of 20cm between the radiator and your body. This transmitter must not be co-located or operating in conjunction with any other antenna or transmitter.

**Industry Canada (IC) certifications:** This digital apparatus does not exceed the Class B limits for radio noise emissions from digital apparatus set out in the Radio Interference Regulations of the Canadian Department of Communications.

Le présent appareil numérique n'émet pas de bruits radioélectriques dépassant les limites applicables aux appareils numériques de la classe B prescrites dans le Règlement sur le brouillage radioélectrique édicté par le ministère des Communications du Canada.

FCC certifications and regulatory information (USA only)

**FCC Part 15 Class B:** This device complies with part 15 of the FCC rules. Operation is subject to the following two conditions: (1) These devices may not cause harmful interference, and (2) These devices must accept any interference received, including interference that may cause harmful operation.

**RADIO FREQUENCY INTERFERENCE (RFI) (FCC 15.105):** This equipment has been tested and found to comply with the limits for a Class B digital device, pursuant to Part 15 of the FCC rules. These limits are designed to provide reasonable protection against harmful interference in a residential installation. This equipment generates, uses, and can radiate radio frequency energy and, if not installed and used in accordance with the instructions, may cause harmful interference to radio communications. However, there is no guarantee that interference will not occur in a particular installation. If this equipment does cause harmful interference to radio or television reception, which can be determined by turning the equipment off and on, the user is encouraged to try to correct the interference by one or more of the following measures: (1) Re-orient or relocate the receiving antenna; (2) Increase the separation between the equipment and the receiver; (3) Connect the equipment into an outlet on a circuit different from that to which the receiver is connected; (4) Consult the dealer or an experienced radio/TV technician for help.

**Declaration of Conformity (FCC 96-208 & 95-19):** Synapse Wireless, Inc. declares that the product name CSEN1 to which this declaration relates, meet the requirements specified by the Federal Communications Commission as detailed in the following specifications:

- Part 15, Subpart B, for Class B equipment
- FCC 96-208 as it applies to Class B personal computers and peripherals
- This product has been tested at an External Test Laboratory certified per FCC rules and has been found to meet the FCC, Part 15, Emission Limits. Documentation is on file and available from Synapse Wireless, Inc.

If the FCC ID for the module inside this product enclosure is not visible when installed inside another device, then the outside of the device into which this product is installed must also display a label referring to the enclosed module FCC ID. Modifications (FCC 15.21): Changes or modifications to this equipment not expressly approved by Synapse Wireless, Inc., may void the user's authority to operate this equipment.

Patented – virtual marking at

<https://www.synapsewireless.com/about/patents>

To learn more visit: [synapsewireless.com](https://www.synapsewireless.com)

## CERTIFICATIONS

**Model** : CSEN1-H-W-ZHA (white enclosure) or CSEN1-H-G-ZHA (gray enclosure)  
**Contains FCC ID** : QOQ-GM240P  
**Contains IC** : 5123A-GM240P  
**RoHS 3** : 2011/65/EU (2015/863)  
**EU REACH** : (EC) No 1907/2006  
**CE**  
**UKCA**

**DALI-2 Certified Application Controller**

